

SHORT COMMUNICATION

Recovery of electric power by direct chlorination of hydrogen or hydrocarbons in a high temperature fuel cell

S. YOSHIZAWA, Z. TAKEHARA, Y. ITO, Y. NAKANISHI and Y. KOYAMA

Department of Industrial Chemistry, Faculty of Engineering, Kyoto University, Yoshida, Kyoto, Japan

Received 1 June 1973

1. Introduction

The commercial use of cells for the simultaneous production of electric energy and marketable chemicals formed by the cell reactions is an interesting problem. Hydrogen chloride may be produced by the combustion of hydrogen and chlorine, but this reaction is also accompanied by a large dissipation of heat. By the use of the following fuel cells, hydrogen chloride can be produced with electric power,

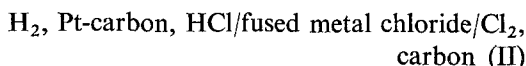
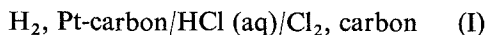

In cell (II), a eutectic melt of KCl and LiCl is used as the electrolyte. Also, the energy dissipated in the chlorination of hydrocarbons can be recovered as electric power by the use of hydrocarbons in place of hydrogen in these types of cell.

In cells I and II the following reaction takes place

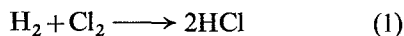

With cell I, the overpotential of the hydrogen electrode is very high and the catalysts for the hydrogen electrode are corroded gradually by the electrolyte. Therefore, in order to obtain a higher yield of electrical energy at high current discharge and longer cell life, cell II of the high temperature type has been considered.

The polarization characteristics of both the hydrogen and chlorine electrodes have been

measured experimentally and the discharge mechanism of this cell discussed. To construct the actual cell, a paste electrolyte of α -alumina with a eutectic mixture of potassium chloride and lithium chloride has been used. The possibility of the use of hydrocarbons in place of hydrogen in cell II has also been considered.

2. Experimental technique

Cylindrical graphite with porous carbon at the end was employed as the supporting material of the hydrogen (hydrocarbon) or chlorine electrode, as shown in Fig. 1. Porous carbon (surface area—0.68 cm²; porosity—50%; mean radius of

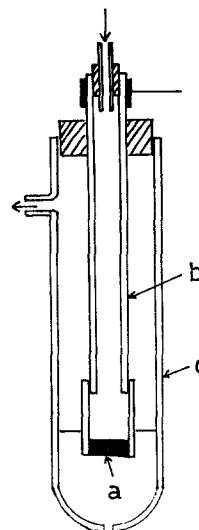

Fig. 1. Gas electrode. a—porous carbon gas electrode; b—impervious graphite tube; c—pyrex glass tube.

pores—60 μm) was used as the electrodes. In some cases, platinum impregnated in the pores of porous carbon by thermal decomposition of chloroplatinic acid solution was used as a catalyst of the hydrogen or hydrocarbon electrode. To protect the electrodes from wetting by the electrolyte, hydrogen or chlorine was bubbled from the electrode into the electrolyte at a flux of $100\sim 150\text{ ml min}^{-1}\text{ cm}^{-2}$.

The polarization characteristics at the discharge with constant current on both the hydrogen (hydrocarbon) and chlorine electrodes were measured in reference to the chlorine electrode. Aqueous solutions of hydrogen chloride in cell I and the molten salt of potassium chloride (42 mol %) and lithium chloride (58 mol %) in cell II were used as the electrolyte. Fig. 2 shows the

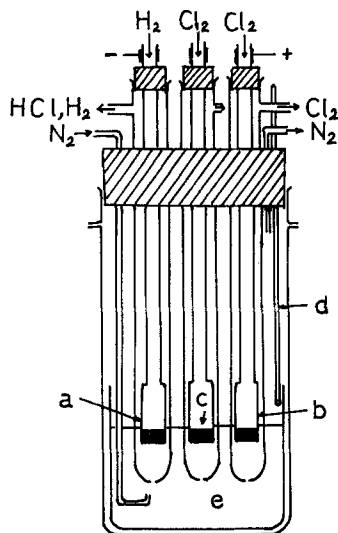

Fig. 2. Experimental cell. a—hydrogen (hydrocarbons) electrode; b—chlorine electrode; c—reference (Cl_2/Cl^-) electrode; d—thermocouple; e—electrolyte ($\text{KCl}\cdot\text{LiCl}$).

experimental cell at high temperature. In cell II a pyrex-glass tube with a pin-hole (1 mm in diameter) to prevent the gas mixing, was used. The ohmic resistances of the supporting material of the electrode and the electrolyte were eliminated by the current interruption method.

3. Comparison of cells I and II

The electromotive forces for both types of cell were determined from the equilibrium potentials of hydrogen on the platinized porous carbon in

reference to chlorine on the porous carbon. The electromotive force of cell I with 5N HCl at 50°C was 1.24 V and that of cell II in a nitrogen atmosphere at 500°C was 1.60 V. Thus when polarization is neglected, the electric energy recovered per 1 kg HCl is 912 Wh for cell I and 1180 Wh for cell II.

Polarization performances for both type cells were measured as shown in Fig. 3. Polarizations

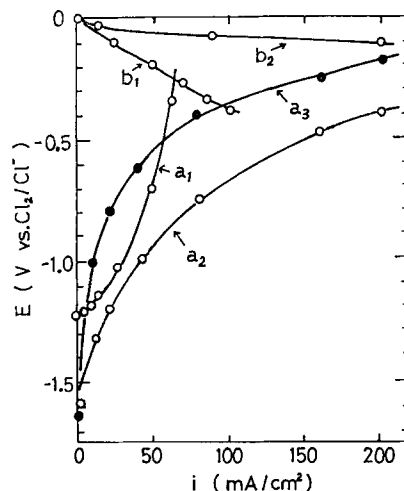

Fig. 3. Polarization curves for cell I and cell II. a—anodic polarization curves of the hydrogen electrode; b—cathodic polarization curves of the chlorine electrode; a_1, b_1 —in 5N HCl at 50°C ; a_2, a_3, b_2 —in $\text{KCl}\cdot\text{LiCl}$ at 500°C ; a_1, a_2 —on porous carbon with platinum catalyst; a_3, b_1, b_2 —on porous carbon without catalyst.

at hydrogen and chlorine electrodes in cell II were lower than those in cell I. From the data in Fig. 3, the characteristics of the hydrogen-chlorine cells of 5 mm distance between electrodes, were also summarized by considering the ohmic drop in the electrolyte in Fig. 4. When the cell II was operated at a current density of 100 mA cm^{-2} at 500°C , a cell voltage of about 0.6 V and electric energy of about 6 W dm^{-2} may be obtained. In cell I the electromotive force showed 1.24 V at 50°C , but the cell voltage showed zero at a current density of 50 mA cm^{-2} .

Comparing the performances of the low- and the high-temperature cell, one recognizes that the latter gives better results.

4. Life time and current efficiency of cell II

The platinum catalyst dissolved in the molten

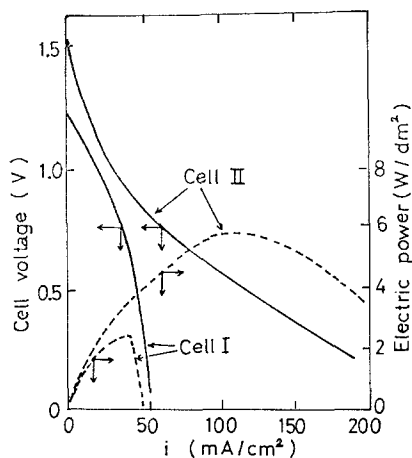

Fig. 4. Cell voltages and electric powers of cell I and II assuming electrode interval of 5 mm. cell I: $\text{H}_2|\text{5N HCl}|\text{Cl}_2$ at 50°C ; cell II: $\text{H}_2|\text{KCl}\cdot\text{LiCl}|\text{Cl}_2$ at 500°C .

salt of lithium chloride and potassium chloride when the electrode was polarized more anodically than the potential of about -0.5 V versus chlorine electrode. Thus, the life of the hydrogen electrode with a platinum catalyst was more than 100 h at a discharge of 100 mA cm^{-2} , but was very short at a discharge of more than 150 mA cm^{-2} . Therefore, in the cell with longer life, the use of the carbon electrode without catalyst on the hydrogen electrode may be expected. The ionization overpotential of hydrogen at the electrode without catalyst was somewhat higher than that with catalyst as shown in Fig. 3. The current efficiency at discharge by the use of a hydrogen electrode with platinum catalyst was measured at 500°C in a nitrogen atmosphere. At the hydrogen electrode, hydrogen chloride only was evolved and this evolved hydrogen chloride was caught at the hydrogen department of the cell, resulting in 96% current efficiency at 10 mA cm^{-2} and 98% at 200 mA cm^{-2} . At the chlorine compartment, hydrogen chloride was not caught. These results suggest that the discharge reactions at both the electrodes are as follows:

At the hydrogen electrode



At the chlorine electrode

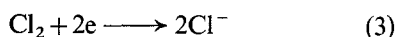

5. Electrolyte of cell II

In the actual high-temperature cell the electrolyte must be fixed in the cell. Thus a paste consisting of α -alumina and the eutectic mixture of potassium chloride and lithium chloride was adopted. α -alumina was prepared by the thermal treatment of the activated alumina (200~300 mesh). During the preliminary test, it was found that the paste electrolyte containing more than 40 wt % α -alumina, was physically stable. And then, electrical conductivities of the paste electrolytes were measured as shown in Fig. 5. The

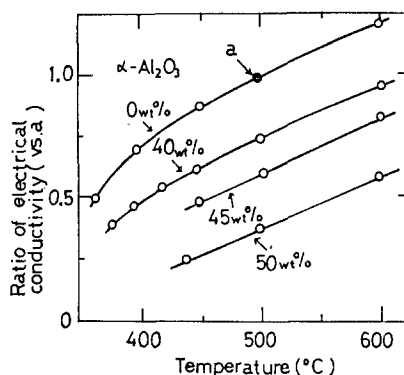

Fig. 5. Electrical conductivities of the paste matrix in reference to the pure electrolyte $[\text{KCl} (42\text{ mol. \%})\cdot\text{LiCl} (58\text{ mol. \%})]$.

paste electrolyte prepared from 40 wt % of α -alumina and 60 wt % of eutectic electrolyte showed electrical conductivity of about 75% of pure eutectic electrolyte at 500°C .

Therefore, a paste consisting of 40 wt % of α -alumina and 60 wt % of a eutectic mixture of potassium chloride and lithium chloride as the electrolyte was adopted. By the use of this paste electrolyte, a cylindrical high-temperature type cell as shown in Fig. 6 was constructed. In this cell, the inner tube (effective surface area— 123 cm^2 ; thickness— 1.0 cm) was the chlorine electrode prepared by porous carbon, and the outer tube (effective surface area— 151 cm^2 ; thickness— 1.0 cm) was the hydrogen electrode prepared by platinized porous carbon. The thickness of the paste electrolyte was 1.0 cm . With this cell the electromotive force was about 1.0 V and the cell voltage at 500°C was about 0.74 V at a current of 1.0 A and about 0.45 V at a current of 3.0 A and the cell life was more than 100 h. These discharge

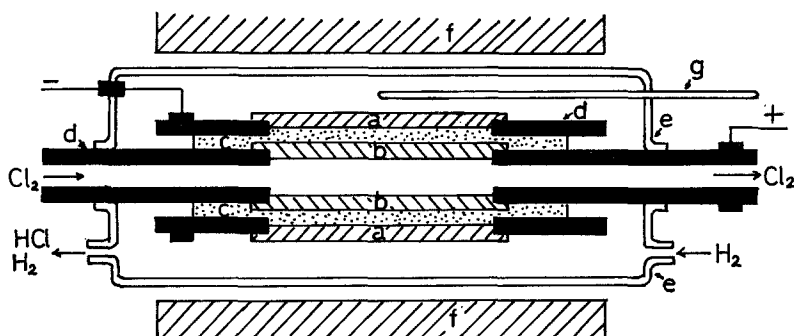

Fig. 6. Scheme of a cylindrical high temperature hydrogen-chlorine cell. a—hydrogen electrode; b—chlorine electrode; c—paste matrix (40 wt % α - Al_2O_3 , 60 wt % KCl-LiCl melt); d—impervious graphite tube; e—alumina tube; f—electric furnace; g—thermocouple.

performances were not better than those of the cell which did not use paste electrolyte, but by improving the electrode structure, better discharge performances may be expected.

6. Possibility of hydrocarbons as active mass

The possibility of the direct anodic chlorination of various hydrocarbons in cell II was examined. Methane (99.9%), propane (96.5%), *n*-butane (99.4%), ethylene (99.0%), propylene (95.5%, propane 4.2%), butene-1 (99.8%) and butadiene (92.0%, butene-2 3.9%, Butene-1 2.5%) were used as hydrocarbons. From the preliminary experiment with cyclic voltammetry it was found to be possible for methane, ethylene and propylene to undergo direct anodic chlorination in molten salt of potassium chloride and lithium chloride. And the products of the anodic oxidation of methane were found, by means of the electron capture type gas chromatography, to be CH_3Cl , CH_2Cl_2 , CHCl_3 , CCl_4 and $\text{CHCl}_2 \cdot \text{CHCl}_2$ at 400°C . Current efficiency of the anodic oxidation of methane at 400°C was also measured from the determination of hydrogen chloride produced and was found to be 91.0% at 10 mA cm^{-2} and 79.5% at 20 mA cm^{-2} by considering the following reaction



Polarization performances for various hydrocarbon electrodes were measured. Ethylene was the most active, but showed higher polarization than hydrogen. Platinum dissolved in the molten salt when the electrode was polarized more

anodically than the potential of about -0.5 V versus chlorine electrode, so the life time of the catalyst was very short. Thus, the use of the carbon electrode without a catalyst was examined. In the case of use of this electrode, anodic polarization curves of various hydrocarbons were measured as shown in Fig. 7. Above 500°C , hydrocarbons were decomposed to carbon and hydrogen, and the anodic current obtained was appreciably larger than that obtained below 400°C , where no cracking took place and only the direct anodic chlorination of hydrocarbons could occur. When ethylene was used at 500°C , a cell voltage of 0.2 V may be obtained at a current density of 50 mA cm^{-2} by estimation from Fig. 7.

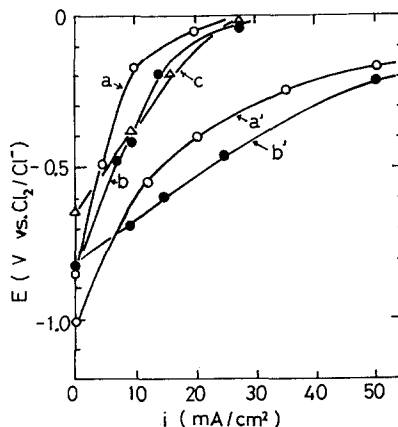

Fig. 7. Anodic polarization curves by the use of the electrode without catalyst under steady state condition. a, a'—under methane passing; b, b'—under ethylene passing; c—under propylene passing; a, b, c—at 400°C ; a', b'—at 500°C .

The characteristics of this cell do not seem very promising and even considering that better performance can be obtained by improving the anode structure or by finding an effective and stable catalyst for the anode, it seems more desirable to employ another process as described in [1], where a three-dimensional gas-liquid reaction is achieved between hydrocarbons and a

chloride melt containing cuprous chloride, and subsequently cupric chloride is formed by anodic oxidation.

Reference

- [1] S. Yoshizawa, Z. Takehara, Y. Ito and H. Inoguchi, to be published.